

Velo-Doku



ARGON 18



20

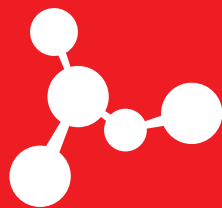

17

www.argon18bike.com

12.09.16



ROAD

Nitrogen Pro

Shimano Dura Ace Di2
 Shimano Dura Ace
 Shimano Ultegra Di2
 Shimano Ultegra
 Sram Red E-Tap
 Sram Red

ab CHF 8'495.-
 ab CHF 7'095.-
 ab CHF 6'695.-
 ab CHF 5'895.-
 ab CHF 7'795.-
 ab CHF 6'695.-



schwarz-/grau matt



Nitrogen

Shimano Dura Ace Di2
 Shimano Dura Ace
 Shimano Ultegra Di2
 Shimano Ultegra
 Sram Red E-Tap
 Sram Red

ab CHF 7'095.-
 ab CHF 5'695.-
 ab CHF 5'295.-
 ab CHF 4'495.-
 ab CHF 6'295.-
 ab CHF 5'295.-



schwarz/weiss



Gallium Pro

Shimano Dura Ace Di2
 Shimano Dura Ace
 Shimano Ultegra Di2
 Shimano Ultegra
 Sram Red E-Tap
 Sram Red

ab CHF 7'195.-
 ab CHF 5'795.-
 ab CHF 5'395.-
 ab CHF 4'595.-
 ab CHF 6'495.-
 ab CHF 5'495.-



schwarz matt/rot



Gallium

Shimano Ultegra Di2
 Shimano Ultegra
 Shimano 105
 Sram Force 22

ab CHF 4'495.-
 ab CHF 3'695.-
 ab CHF 3'295.-
 ab CHF 3'895.-



schwarz/weiss





ROAD

Krypton XRoad

Shimano Ultegra Di2 ab CHF 4'595.-
 Shimano Ultegra ab CHF 3'695.-
 Shimano 105 ab CHF 3'295.-



schwarz matt/weiss

Krypton

Shimano Ultegra Di2 ab CHF 3'795.-
 Shimano Ultegra ab CHF 2'995.-
 Shimano 105 ab CHF 2'695.-
 Sram Force 22 ab CHF 3'195.-



schwarz matt/rot



TRIATHLON

E-119 TRI+

Shimano Dura Ace Di2 ab CHF 9'995.-
 Shimano Dura Ace ab CHF 8'295.-
 Shimano Ultegra Di2 ab CHF 8'595.-
 Shimano Ultegra ab CHF 7'395.-
 Sram Red E-Tap ab CHF 9'295.-
 Sram Red ab CHF 8'595.-



schwarz matt

E-119 TRI

Shimano Dura Ace Di2 ab CHF 9'295.-
 Shimano Dura Ace ab CHF 7'595.-
 Shimano Ultegra Di2 ab CHF 7'895.-
 Shimano Ultegra ab CHF 6'695.-
 Sram Red E-Tap ab CHF 8'495.-
 Sram Red ab CHF 7'795.-



schwarz glanz/rot

TIME TRIAL & TRIATHLON

E-117 TRI

Shimano Ultegra Di2 ab CHF 5'195.-
 Shimano Ultegra ab CHF 3'995.-
 Shimano 105 ab CHF 3'695.-



schwarz matt





Schaltgruppe		Compact	2-fach
Dura Ace Di2	CHF 8'495.-	<input type="checkbox"/> 34/50	<input type="checkbox"/> 36/52
Dura Ace	CHF 7'095.-	<input type="checkbox"/> 34/50	<input type="checkbox"/> 36/52
Ultegra Di2	CHF 6'695.-	<input type="checkbox"/> 34/50	<input type="checkbox"/> 36/52
Ultegra	CHF 5'895.-	<input type="checkbox"/> 34/50	<input type="checkbox"/> 36/52
Sram Red eTap	CHF 7'795.-	<input type="checkbox"/> 34/50	<input type="checkbox"/> 36/52
Sram Red	CHF 6'695.-	<input type="checkbox"/> 34/50	<input type="checkbox"/> 36/52

Rahmen Argon18 Nitrogen Pro Carbon Monocoque, Gewicht ca. 833 g

Gabel Argon18 Nitrogen Pro Carbon Monocoque

Grösse XS/520 mm S/537 mm M/556 mm L/575 mm XL/595 mm

Farbe schwarz-/grau matt

Kabel schwarz

Kassette	11-23	11-25	11-26	11-28	11-30	11-32	12-25	12-28
Dura Ace		<input type="checkbox"/>		<input type="checkbox"/>	<input type="checkbox"/>		<input type="checkbox"/>	<input type="checkbox"/>
Ultegra	<input type="checkbox"/>	<input type="checkbox"/>		<input type="checkbox"/>		<input type="checkbox"/>	<input type="checkbox"/>	
Red		<input type="checkbox"/>	<input type="checkbox"/>	<input type="checkbox"/>	<input type="checkbox"/>	<input type="checkbox"/>		

Kurbel

Länge 170 mm 172,5 mm 175 mm Red Quarq Powermeter (nur für Sram) **+900.-**

Kurbel Rotor IN-Power 3D+ **Dura Ace: +475.- / Ultegra: +850.- / Sram: +625.-**

Kettenblätter: Classic rund Classic Q-Rings **+25.-**

Cockpit

Typ Argon18 Nitrogen Pro

Vorbau 80 mm 90 mm 100 mm 110 mm 120 mm 130 mm

Lenker 40 cm 42 cm 44 cm

Stütze Argon18 Nitrogen Pro

Sattel

Astute StarLab SR Selle Italia SLR Ti

fi'zi:k Arione R5 Wing Flex Selle Italia SLR Flow

fi'zi:k Arione Donna Wing Flex Selle Italia Lady Flow

Laufräder

Fulcrum Racing Quattro Fulcrum Racing Zero NITE **+950.-**

Fulcrum Racing Zero **+550.-** Zipp 303 CCL **+1'900.-**

Bereifung

Michelin Pro 4 Race schwarz 23mm Continental Grand Prix 4000S II schwarz 23mm

Schwalbe One V-Guard schwarz 23mm Continental Grand Prix 4000S II schwarz 25mm

Preis- und Spezifikationsänderungen vorbehalten, alle Preise in CHF inkl. MwSt.

KUNDENDATEN

Name _____

Adresse _____

Tel _____

Ort/Datum _____

BEMERKUNGEN

Liefertermin _____

Preis Total _____ **CHF**

Unterschrift Kunde _____

Unterschrift / Stempel Händler _____



Schaltgruppe		Compact	2-fach
Dura Ace Di2	CHF 7'095.-	<input type="checkbox"/> 34/50	<input type="checkbox"/> 36/52
Dura Ace	CHF 5'695.-	<input type="checkbox"/> 34/50	<input type="checkbox"/> 36/52
Ultegra Di2	CHF 5'295.-	<input type="checkbox"/> 34/50	<input type="checkbox"/> 36/52
Ultegra	CHF 4'495.-	<input type="checkbox"/> 34/50	<input type="checkbox"/> 36/52
Sram Red eTap	CHF 6'295.-	<input type="checkbox"/> 34/50	<input type="checkbox"/> 36/52
Sram Red	CHF 5'295.-	<input type="checkbox"/> 34/50	<input type="checkbox"/> 36/52

Rahmen Argon18 Nitrogen Carbon Monocoque, Gewicht ca. 990 g

Gabel Argon18 Nitrogen Carbon Monocoque

Grösse XS/520 mm S/537 mm M/556 mm L/575 mm XL/595 mm

Farbe schwarz/weiss

Kabel schwarz

Kassette

	11-23	11-25	11-26	11-28	11-30	11-32	12-25	12-28
Dura Ace		<input type="checkbox"/>		<input type="checkbox"/>	<input type="checkbox"/>		<input type="checkbox"/>	<input type="checkbox"/>
Ultegra	<input type="checkbox"/>	<input type="checkbox"/>		<input type="checkbox"/>		<input type="checkbox"/>	<input type="checkbox"/>	
Red		<input type="checkbox"/>	<input type="checkbox"/>	<input type="checkbox"/>	<input type="checkbox"/>	<input type="checkbox"/>		

Kurbel

Länge 170 mm 172,5 mm 175 mm Red Quarq Powermeter (nur für Sram) **+900.-**

Kurbel Rotor IN-Power 3D+ **Dura Ace: +475.- / Ultegra: +850.- / Sram: +625.-**

Kettenblätter: Classic rund Classic Q-Rings **+25.-**

Cockpit

Typ 3T Pro 3T Team/LTD Stealth (Carbon) **+375.-**

Vorbau 3T Arx Pro 6°/84°

80 mm 90 mm 100 mm 110 mm 120 mm 130 mm

Lenker 3T Ergonova Pro 3T Aeronova Team Stealth (bei 3T Pro) **+150.-**

40 cm 42 cm 44 cm

Stütze Argon18 Nitrogen

Sattel

Astute StarLab SR Selle Italia SLR Ti

fi'zi:k Arione R5 Wing Flex Selle Italia SLR Flow

fi'zi:k Arione Donna Wing Flex Selle Italia Lady Flow

Laufräder

Fulcrum Racing 3 Fulcrum Racing Zero NITE **+800.-**

Fulcrum Racing Zero **+400.-** Zipp 303 CCL **+1'750.-**

Bereifung

Michelin Pro 4 Race schwarz 23mm Continental Grand Prix 4000S II schwarz 23mm

Schwalbe One V-Guard schwarz 23mm Continental Grand Prix 4000S II schwarz 25mm

Preis- und Spezifikationsänderungen vorbehalten, alle Preise in CHF inkl. MwSt.

KUNDENDATEN

Name _____

Adresse _____

Tel _____

Ort/Datum _____

BEMERKUNGEN

Liefertermin _____

Preis Total **CHF**

Unterschrift Kunde _____

Unterschrift / Stempel Händler _____



Schaltgruppe		Compact	2-fach
Dura Ace Di2	CHF 7'195.-	<input type="checkbox"/> 34/50	<input type="checkbox"/> 36/52
Dura Ace	CHF 5'795.-	<input type="checkbox"/> 34/50	<input type="checkbox"/> 36/52
Ultegra Di2	CHF 5'395.-	<input type="checkbox"/> 34/50	<input type="checkbox"/> 36/52
Ultegra	CHF 4'595.-	<input type="checkbox"/> 34/50	<input type="checkbox"/> 36/52
Sram Red eTap	CHF 6'495.-	<input type="checkbox"/> 34/50	<input type="checkbox"/> 36/52
Sram Red	CHF 5'495.-	<input type="checkbox"/> 34/50	<input type="checkbox"/> 36/52

Rahmen Argon18 Gallium Pro Carbon Monocoque, Gewicht ca. 790g

Gabel Argon18 Gallium Pro Carbon Monocoque
 Grösse XXS/502 mm XS/520 mm S/540 mm M/560 mm L/575 mm XL/595 mm
 Farbe schwarz matt/rot
 Kabel schwarz

Kassette	11-23	11-25	11-26	11-28	11-30	11-32	12-25	12-28
Dura Ace		<input type="checkbox"/>		<input type="checkbox"/>	<input type="checkbox"/>		<input type="checkbox"/>	<input type="checkbox"/>
Ultegra	<input type="checkbox"/>	<input type="checkbox"/>		<input type="checkbox"/>		<input type="checkbox"/>	<input type="checkbox"/>	
Red		<input type="checkbox"/>	<input type="checkbox"/>	<input type="checkbox"/>	<input type="checkbox"/>	<input type="checkbox"/>		

Kurbel
 Länge 170 mm 172,5 mm 175 mm Red Quarq Powermeter (nur für Sram) **+900.-**
 Kurbel Rotor IN-Power 3D+ **Dura Ace: +475.- / Ultegra: +850.- / Sram: +625.-**
 Kettenblätter: Classic rund Classic Q-Rings **+25.-**

Cockpit
 Typ 3T Pro 3T Team/LTD Stealth (Carbon) **+375.-**
 Vorbau 3T Arx Pro 6°/84°
 80 mm 90 mm 100 mm 110 mm 120 mm 130 mm
 Lenker 3T Ergonova Pro 3T Aeronova Team Stealth (bei 3T Pro) **+150.-**
 40 cm 42 cm 44 cm
 Stütze Argon18 Gallium Pro

Sattel
 Astute StarLab SR Selle Italia SLR Ti
 fi'zi:k Arione R5 Wing Flex Selle Italia SLR Flow
 fi'zi:k Arione Donna Wing Flex Selle Italia Lady Flow

Laufräder
 Fulcrum Racing 3 Fulcrum Racing Zero NITE **+800.-**
 Fulcrum Racing Zero **+400.-** Zipp 303 CCL **+1'750.-**

Bereifung
 Michelin Pro 4 Race schwarz 23mm Continental Grand Prix 4000S II schwarz 23mm
 Schwalbe One V-Guard schwarz 23mm Continental Grand Prix 4000S II schwarz 25mm

Preis- und Spezifikationsänderungen vorbehalten, alle Preise in CHF inkl. MwSt.

KUNDENDATEN

Name _____
 Adresse _____
 Tel _____
 Ort/Datum _____

Unterschrift Kunde _____

BEMERKUNGEN

Liefertermin _____
Preis Total **CHF**

Unterschrift / Stempel Händler _____



Schaltgruppe

Compact 2-fach

Ultegra Di2	CHF 4'495.-	<input type="checkbox"/> 34/50	<input type="checkbox"/> 36/52
Ultegra	CHF 3'695.-	<input type="checkbox"/> 34/50	<input type="checkbox"/> 36/52
105	CHF 3'295.-	<input type="checkbox"/> 34/50	<input type="checkbox"/> 36/52
Sram Force 22	CHF 3'895.-	<input type="checkbox"/> 34/50	<input type="checkbox"/> 36/52

Rahmen Argon18 Gallium Carbon Monocoque, Gewicht ca. 965g

Gabel Argon18 Gallium Carbon Monocoque

Grösse XS/520 mm S/540 mm M/560 mm L/575 mm XL/595 mm

Farbe schwarz/weiss

Kabel schwarz

Kassette	11-23	11-25	11-26	11-28	11-30	11-32	12-25	12-28
Ultegra	<input type="checkbox"/>	<input type="checkbox"/>		<input type="checkbox"/>		<input type="checkbox"/>	<input type="checkbox"/>	
105				<input type="checkbox"/>		<input type="checkbox"/>	<input type="checkbox"/>	
Force		<input type="checkbox"/>	<input type="checkbox"/>			<input type="checkbox"/>		

Kurbel

Länge 170 mm 172,5 mm 175 mm

Cockpit

Typ 3T Pro 3T Team/LTD Stealth (Carbon) **+375.-**

Vorbau 3T Arx Pro 6°/84°

 80 mm 90 mm 100 mm 110 mm 120 mm 130 mmLenker 3T Ergonova Pro 3T Aeronova Team Stealth (bei 3T Pro) **+150.-** 40 cm 42 cm 44 cm

Stütze Argon18 Gallium

Sattel

 Astute StarLab SR Selle Italia SLR Ti fi'zi:k Arione R5 Wing Flex Selle Italia SLR Flow fi'zi:k Arione Donna Wing Flex Selle Italia Lady Flow

Laufräder

 Fulcrum Racing 7 Fulcrum Racing Zero **+700.-** Fulcrum Racing 3 **+325.-** Fulcrum Racing Zero NITE **+1'100.-**

Bereifung

 Michelin Pro 4 Race schwarz 23mm Continental Grand Prix 4000S II schwarz 23mm Schwalbe One V-Guard schwarz 23mm Continental Grand Prix 4000S II schwarz 25mm

Preis- und Spezifikationsänderungen vorbehalten, alle Preise in CHF inkl. MwSt.

KUNDENDATEN

Name

Adresse

Tel

Ort/Datum

Unterschrift Kunde

BEMERKUNGEN

Liefertermin

Preis Total

CHF

Unterschrift / Stempel Händler



Schaltgruppe		Compact	2-fach
Ultegra Di2	CHF 4'595.-	<input type="checkbox"/> 34/50	<input type="checkbox"/> 36/52
Ultegra	CHF 3'695.-	<input type="checkbox"/> 34/50	<input type="checkbox"/> 36/52
105	CHF 3'295.-	<input type="checkbox"/> 34/50	<input type="checkbox"/> 36/52

Rahmen Argon18 Krypton Xroad Carbon Monocoque, Gewicht ca. 1190g
 Gabel Argon18 Krypton Xroad Carbon Monocoque
 Grösse XS/520 mm S/535 mm M/550 mm L/570 mm XL/590 mm
 Farbe schwarz-/weiss matt
 Kabel schwarz

Kassette	11-23	11-25	11-26	11-28	11-30	11-32	12-25	12-28
Ultegra	<input type="checkbox"/>	<input type="checkbox"/>		<input type="checkbox"/>		<input type="checkbox"/>	<input type="checkbox"/>	
105				<input type="checkbox"/>		<input type="checkbox"/>	<input type="checkbox"/>	

Kurbel
 Länge 170 mm 172,5 mm 175 mm

Cockpit
 Typ 3T Pro
 Vorbau 3T Arx Pro 6°/84°
 80 mm 90 mm 100 mm 110 mm 120 mm 130 mm
 Lenker 3T Ergonova Pro 40 cm 42 cm 44 cm
 Stütze Argon18 Krypton Xroad

Sattel
 Selle Italia SLS Flow fi'zi:k Arione R5 Wing Flex **+25.-**
 Selle Italia Lady Flow Selle Italia SLR Ti **+25.-**
 fi'zi:k Arione Donna Wing Flex

Laufräder
 DT R23 Spline Disc Zipp 30 Course Disc **+600.-**
 Fulcrum Racing 5 Disc **+50.-** Fulcrum Quattro Carbon Disc **+1'200.-**

Bereifung
 Continental Grand Prix 4000S II schwarz 25mm

Preis- und Spezifikationsänderungen vorbehalten, alle Preise in CHF inkl. MwSt.

KUNDENDATEN

Name _____
 Adresse _____
 Tel _____
 Ort/Datum _____

BEMERKUNGEN

Liefertermin _____
Preis Total **CHF**

Unterschrift Kunde _____

Unterschrift / Stempel Händler _____



Schaltgruppe		Compact	2-fach
Ultegra Di2	CHF 3'795.-	<input type="checkbox"/> 34/50	<input type="checkbox"/> 36/52
Ultegra	CHF 2'995.-	<input type="checkbox"/> 34/50	<input type="checkbox"/> 36/52
105	CHF 2'695.-	<input type="checkbox"/> 34/50	<input type="checkbox"/> 36/52
Sram Force 22	CHF 3'195.-	<input type="checkbox"/> 34/50	<input type="checkbox"/> 36/52

Rahmen Argon18 Krypton Carbon Monocoque, Gewicht ca. 1190g

Gabel Argon18 Krypton Carbon Monocoque

Grösse XS/520 mm S/540 mm M/556 mm L/575 mm XL/595 mm

Farbe schwarz matt/rot

Kabel schwarz

Kassette	11-23	11-25	11-26	11-28	11-30	11-32	12-25	12-28
Ultegra	<input type="checkbox"/>	<input type="checkbox"/>		<input type="checkbox"/>		<input type="checkbox"/>	<input type="checkbox"/>	
105				<input type="checkbox"/>		<input type="checkbox"/>	<input type="checkbox"/>	
Force		<input type="checkbox"/>	<input type="checkbox"/>			<input type="checkbox"/>		

Kurbel

Länge 170 mm 172,5 mm 175 mm

Cockpit

Typ 3T Pro

Vorbau 3T Arx Pro 6°/84°

80 mm 90 mm 100 mm 110 mm 120 mm 130 mm

Lenker 3T Ergonova Pro 40 cm 42 cm 44 cm

Stütze Argon18 Krypton

Sattel

Selle Italia SLS Flow fi'zi:k Arione R5 Wing Flex **+25.-**

Selle Italia Lady Flow Selle Italia SLR Ti **+25.-**

fi'zi:k Arione Donna Wing Flex

Laufräder

Fulcrum Racing 7 Fulcrum Racing Quattro **+150.-**

DT Swiss R32 Spline **+125.-** Zipp 30 Course **+750.-**

Bereifung

Michelin Lithion 2 schwarz 23mm Conti Grand Prix 4000S II schwarz 23mm **+50.-**

Michelin Lithion 2 schwarz 25mm Conti Grand Prix 4000S II schwarz 25mm **+50.-**

Preis- und Spezifikationsänderungen vorbehalten, alle Preise in CHF inkl. MwSt.

KUNDENDATEN

Name _____

Adresse _____

Tel _____

Ort/Datum _____

Unterschrift Kunde _____

BEMERKUNGEN

Liefertermin _____

Preis Total **CHF** _____

Unterschrift / Stempel Händler _____



Schaltgruppe

Compact 2-fach

Dura Ace Di2	CHF 9'995.-	<input type="checkbox"/> 34/50	<input type="checkbox"/> 36/52
Dura Ace	CHF 8'295.-	<input type="checkbox"/> 34/50	<input type="checkbox"/> 36/52
Ultegra Di2	CHF 8'595.-	<input type="checkbox"/> 34/50	<input type="checkbox"/> 36/52
Ultegra	CHF 7'395.-	<input type="checkbox"/> 34/50	<input type="checkbox"/> 36/52
Sram Red eTap	CHF 9'295.-	<input type="checkbox"/> 34/50	<input type="checkbox"/> 36/52
Sram Red	CHF 8'595.-	<input type="checkbox"/> 34/50	<input type="checkbox"/> 36/52

Rahmen Argon18 E-119 TRI+ Carbon Monocoque, Gewicht ca. 1'200g

Gabel Argon18 E-119 TRI+ Carbon Monocoque

Grösse XS/491 mm S/503 mm M/517 mm L/527 mm

Farbe schwarz matt

Kabel schwarz

Kassette	11-23	11-25	11-26	11-28	11-30	11-32	12-25	12-28
Dura Ace		<input type="checkbox"/>		<input type="checkbox"/>	<input type="checkbox"/>		<input type="checkbox"/>	<input type="checkbox"/>
Ultegra	<input type="checkbox"/>	<input type="checkbox"/>		<input type="checkbox"/>		<input type="checkbox"/>	<input type="checkbox"/>	
Red		<input type="checkbox"/>	<input type="checkbox"/>	<input type="checkbox"/>	<input type="checkbox"/>	<input type="checkbox"/>		

Kurbel

Länge 170 mm 172,5 mm 175 mm Red Quarq Powermeter (nur für Sram) **+900.-**

Kurbel Rotor IN-Power 3D+ **Dura Ace: +475.- / Ultegra: +850.- / Sram: +625.-**

Kettenblätter: Aero rund Aero Q-Rings **+50.-**

Cockpit

Typ E-119 Carbon

Sattel

fi'zi:k Ares TRI fi'zi:k Tritone 5.5 **+25.-**

Laufräder

Fulcrum Red Wind H.50 Zipp 404 CCL **+1'050.-**

Fulcrum Racing Quattro Carbon **+350.-** Zipp 808 CCL **+1'350.-**

Bereifung

Michelin Pro 4 Race schwarz 23mm Continental Grand Prix 4000S II schwarz 23mm

Schwalbe One V-Guard schwarz 23mm Continental Grand Prix 4000S II schwarz 25mm

Preis- und Spezifikationsänderungen vorbehalten, alle Preise in CHF inkl. MwSt.

KUNDENDATEN

Name

Adresse

Tel

Ort/Datum

Unterschrift Kunde

BEMERKUNGEN

Liefertermin

Preis Total

CHF

Unterschrift / Stempel Händler



Schaltgruppe		Compact	2-fach
Dura Ace Di2	CHF 9'295.-	<input type="checkbox"/> 34/50	<input type="checkbox"/> 36/52
Dura Ace	CHF 7'595.-	<input type="checkbox"/> 34/50	<input type="checkbox"/> 36/52
Ultegra Di2	CHF 7'895.-	<input type="checkbox"/> 34/50	<input type="checkbox"/> 36/52
Ultegra	CHF 6'695.-	<input type="checkbox"/> 34/50	<input type="checkbox"/> 36/52
Sram Red eTap	CHF 8'495.-	<input type="checkbox"/> 34/50	<input type="checkbox"/> 36/52
Sram Red	CHF 7'795.-	<input type="checkbox"/> 34/50	<input type="checkbox"/> 36/52

Rahmen

Argon18 E-119 TRI Carbon Monocoque, Gewicht ca. 1'310g
 Gabel Argon18 E-119 TRI Carbon Monocoque
 Grösse XS/491 mm S/503 mm M/517 mm L/527 mm
 Farbe schwarz/rot
 Kabel schwarz

Kassette	11-23	11-25	11-26	11-28	11-30	11-32	12-25	12-28
Dura Ace		<input type="checkbox"/>		<input type="checkbox"/>	<input type="checkbox"/>		<input type="checkbox"/>	<input type="checkbox"/>
Ultegra	<input type="checkbox"/>	<input type="checkbox"/>		<input type="checkbox"/>		<input type="checkbox"/>	<input type="checkbox"/>	
Red		<input type="checkbox"/>	<input type="checkbox"/>	<input type="checkbox"/>	<input type="checkbox"/>	<input type="checkbox"/>		

Kurbel

Länge 170 mm 172,5 mm 175 mm Red Quarq Powermeter (nur für Sram) **+900.-**
 Kurbel Rotor IN-Power 3D+ **Dura Ace: +475.- / Ultegra: +850.- / Sram: +625.-**
 Kettenblätter: Aero rund Aero Q-Rings **+50.-**

Cockpit

Typ E-119 Carbon

Sattel

fi'zi:k Ares TRI fi'zi:k Tritone 5.5 **+25.-**

Laufräder

Fulcrum Red Wind H.50 Zipp 404 CCL **+1'050.-**
 Fulcrum Racing Quattro Carbon **+350.-** Zipp 808 CCL **+1'350.-**

Bereifung

Michelin Pro 4 Race schwarz 23mm Continental Grand Prix 4000S II schwarz 23mm
 Schwalbe One V-Guard schwarz 23mm Continental Grand Prix 4000S II schwarz 25mm

Preis- und Spezifikationsänderungen vorbehalten, alle Preise in CHF inkl. MwSt.

KUNDENDATEN

Name _____
 Adresse _____
 Tel _____
 Ort/Datum _____

Unterschrift Kunde _____

BEMERKUNGEN

Liefertermin _____
Preis Total **CHF**

Unterschrift / Stempel Händler _____



Schaltgruppe		Compact	2-fach
Ultegra Di2	CHF 5'195.-	<input type="checkbox"/> 34/50	<input type="checkbox"/> 36/52
Ultegra	CHF 3'995.-	<input type="checkbox"/> 34/50	<input type="checkbox"/> 36/52
105	CHF 3'695.-	<input type="checkbox"/> 34/50	<input type="checkbox"/> 36/52

Rahmen Argon18 E-117 TRI Carbon Monocoque, Gewicht ca. 1'470g

Gabel Argon18 E-117 TRI Carbon Monocoque

Grösse XS/489 mm S/501 mm M/514 mm L/525 mm

Farbe schwarz matt

Kabel schwarz

Kassette

	11-23	11-25	11-26	11-28	11-30	11-32	12-25	12-28
Ultegra	<input type="checkbox"/>	<input type="checkbox"/>		<input type="checkbox"/>		<input type="checkbox"/>	<input type="checkbox"/>	
105				<input type="checkbox"/>		<input type="checkbox"/>	<input type="checkbox"/>	

Kurbel

Länge 170 mm 172,5 mm 175 mm

Cockpit

Typ 3T Pro

Vorbau 3T Arx Pro 6°/84°

80 mm 90 mm 100 mm 110 mm 120 mm 130 mm

Lenker 3T Vola Pro 42 cm

Stütze Argon18 E-117 TRI

Sattel

fi'zi:k Ares TRI fi'zi:k Arione TRI K3 Wing Flex

Laufräder

<input type="checkbox"/> Fulcrum Racing Quattro	<input type="checkbox"/> Fulcrum Racing Quattro Carbon	+1'200.-
<input type="checkbox"/> Fulcrum Red Wind H.50	<input type="checkbox"/> Zipp 404 Carbon CCL	+1'900.-

Bereifung

<input type="checkbox"/> Michelin Lithion 2 schwarz 23mm	<input type="checkbox"/> Conti Grand Prix 4000S II schwarz 23mm	+50.-
<input type="checkbox"/> Michelin Lithion 2 schwarz 25mm	<input type="checkbox"/> Conti Grand Prix 4000S II schwarz 25mm	+50.-

Preis- und Spezifikationsänderungen vorbehalten, alle Preise in CHF inkl. MwSt.

KUNDENDATEN

Name _____

Adresse _____

Tel _____

Ort/Datum _____

Unterschrift Kunde _____

BEMERKUNGEN

Liefertermin _____

Preis Total _____ **CHF**

Unterschrift / Stempel Händler _____



Le
de TOUR.
FRANCE



ARGON 18



Road

	A	B	C	D	H1	H2	H3
NITROGEN PRO / NITROGEN							
XS	433	74,5°	72,0°	520	81	9.6	10.6
S	487	74,0°	72,7°	537	10.9	12.4	13.4
M	515	73,5°	72,7°	556	14.1	15.6	16.6
L	567	73,0°	72,7°	575	16.2	17.7	18.7
XL	596	72,5°	73,0°	595	18.8	20.3	21.3

	A	B	C	D	H1	H2	H3
GALLIUM PRO							
XXS	415	75,5°	71,0°	502	77	91	101
XS	455	74,5°	72,0°	520	82	96	106
S	490	74,0°	72,7°	540	109	123	133
M	530	73,5°	72,7°	560	139	153	163
L	565	73,0°	72,7°	575	162	176	186
XL	595	72,5°	73,0°	595	189	203	213

	A	B	C	D	H1	H2	H3
GALLIUM							
XS	450	74,5°	72,0°	520	82	96	106
S	490	74,0°	72,7°	540	109	123	133
M	535	73,5°	72,7°	560	139	153	163
L	560	73,0°	72,7°	575	162	176	186
XL	590	72,5°	73,0°	595	189	203	213

	A	B	C	D	H1	H2	H3
KRYPTON							
XS	465	74,5°	72,0°	520	100	114	124
S	513	74,0°	72,7°	540	123	137	147
M	550	73,5°	72,7°	556	147	161	171
L	575	73,0°	72,7°	575	173	187	197
XL	600	72,5°	73,0°	595	195	209	219

	A	B	C	D	H1	H2	H3
KRYPTON XROAD							
XS	455	74,5°	71,4°	520	107	121	131
S	500	74,0°	72,0°	535	130	144	154
M	540	73,5°	72,0°	550	152	166	176
L	560	73,0°	72,0°	570	183	197	207
XL	595	72,5°	72,3°	590	212	226	236

Triathlon & Time Trial

	A	B	C	D	H1	H2	H3
E-119 TRI+ / E-119 TRI							
XS	455	78,0°	72,0°	491	60		
S	502	78,0°	72,0°	503	70		
M	516	78,0°	72,0°	517	86		
L	542	78,0°	72,0°	527	112		

	A	B	C	D	H1	H2	H3
E-117 TRI							
XS	461	78,0°	72,0°	489	84		
S	500	78,0°	72,0°	501	95		
M	515	78,0°	72,0°	514	111		
L	547	78,0°	72,0°	525	139		

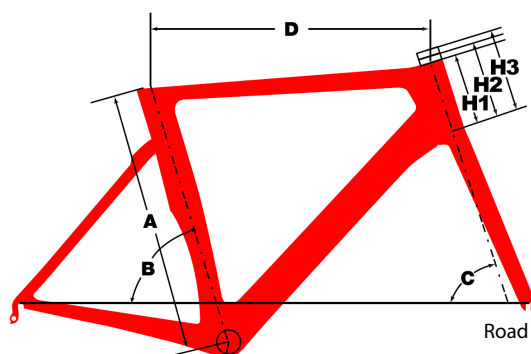

A = Grösse | grandeur
 B = Sitzwinkel | inclination selle
 C = Steuerwinkel | inclination direction
 D = Oberrohrlänge | longueur
 H = Steuerrohrlänge | inclinaison direction

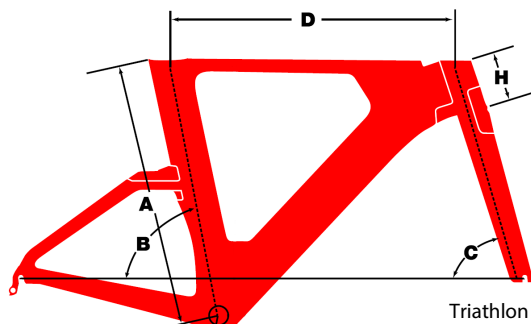

Alle Höhen Mitte Tretlager bis Ende Sitzrohr gemessen,
 alle Längenangaben in Millimeter, alle Winkel in Grad,
 alles unverbindliche Angaben.

Tailles moitié axe – fin tube selle, longueurs en millimètres, toutes les inclinaisons en degrés, toutes les données sans engagement.



Road

NITROGEN PRO

Shimano Dura Ace Di2	8'495.-
Shimano Dura Ace	7'095.-
Shimano Ultegra Di2	6'695.-
Shimano Ultegra	5'895.-
Sram Red E-Tap	7'795.-
Sram Red	6'695.-

NITROGEN

Shimano Dura Ace Di2	7'095.-
Shimano Dura Ace	5'695.-
Shimano Ultegra Di2	5'295.-
Shimano Ultegra	4'495.-
Sram Red E-Tap	6'295.-
Sram Red	5'295.-

GALLIUM PRO

Shimano Dura Ace Di2	7'195.-
Shimano Dura Ace	5'795.-
Shimano Ultegra Di2	5'395.-
Shimano Ultegra	4'595.-
Sram Red E-Tap	6'495.-
Sram Red	5'495.-

GALLIUM

Shimano Ultegra Di2	4'495.-
Shimano Ultegra	3'695.-
Shimano 105	3'295.-
Sram Force 22	3'895.-

KRYPTON Xroad

Shimano Ultegra Di2	4'595.-
Shimano Ultegra	3'695.-
Shimano 105	3'295.-

KRYPTON

Shimano Ultegra Di2	3'795.-
Shimano Ultegra	2'995.-
Shimano 105	2'695.-
Sram Force 22	3'195.-

Triathlon & Time Trial

E-119 TRI+

Shimano Dura Ace Di2	9'995.-
Shimano Dura Ace	8'295.-
Shimano Ultegra Di2	8'595.-
Shimano Ultegra	7'395.-
Sram Red E-Tap	9'295.-
Sram Red	8'595.-

E-119 TRI

Shimano Dura Ace Di2	9'295.-
Shimano Dura Ace	7'595.-
Shimano Ultegra Di2	7'895.-
Shimano Ultegra	6'695.-
Sram Red E-Tap	8'495.-
Sram Red	7'795.-

E-117 TRI

Shimano Ultegra Di2	5'195.-
Shimano Ultegra	3'995.-
Shimano 105	3'695.-



ARGON 18